

Neutral Gas Density and Composition

MANiaC: Mass Analyzer for Neutrals in a Coma

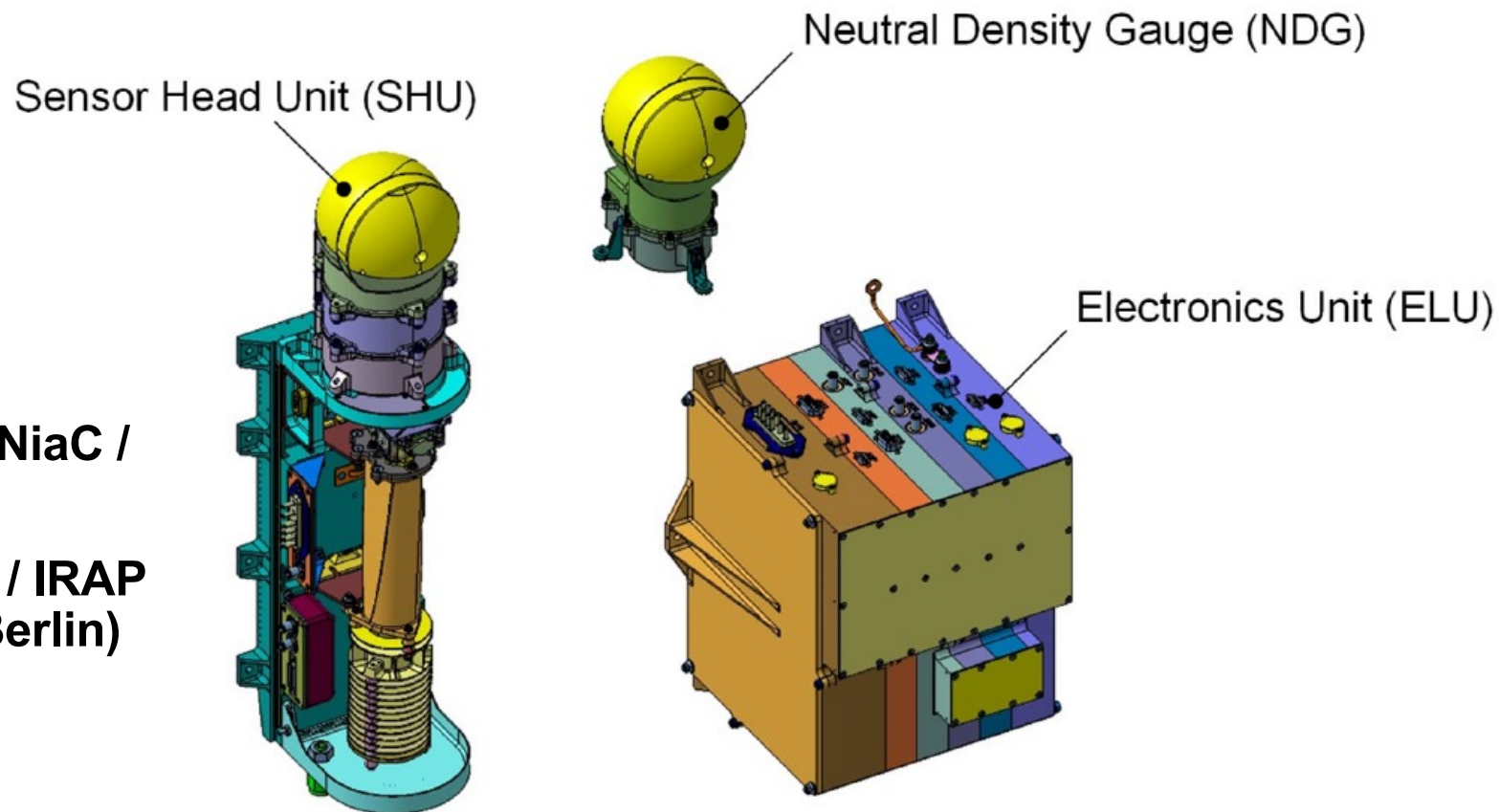

**Martin Rubin on behalf of the MANiaC /
Comet Interceptor Team**

**(U Bern / IWF Graz / IAA Granada / IRAP
Toulouse / CTI Piaseczno / DLR Berlin)**

Oxford, 7 July 2022

Mass Analyzer for Neutrals in a Coma (MANiaC) NDG

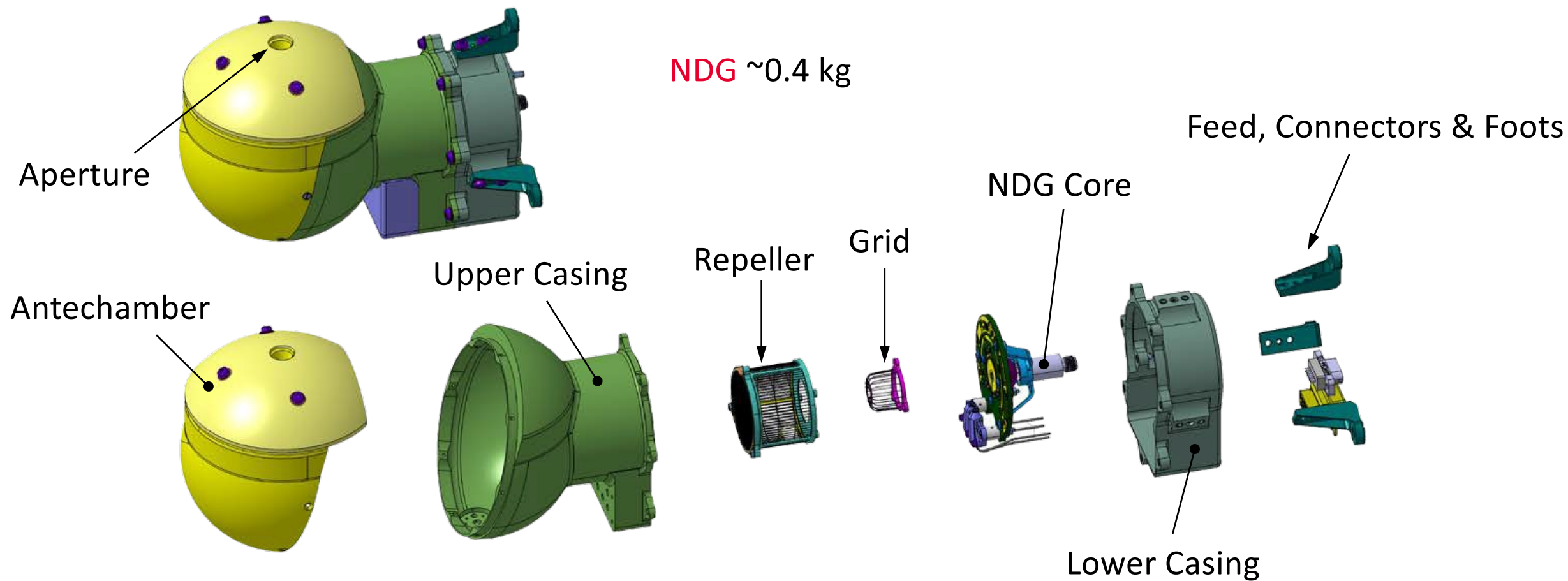

Mass Analyzer for Neutrals in a Coma (MANiaC)

SHU

SHU ~1.7 kg*

Antechamber

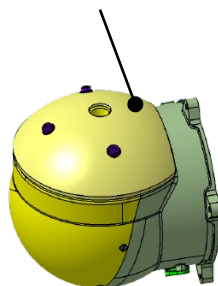

IOS Tube

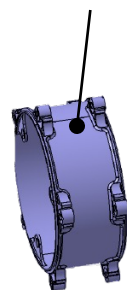

Tube

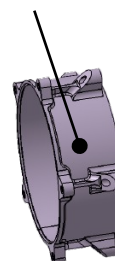

Ion Source

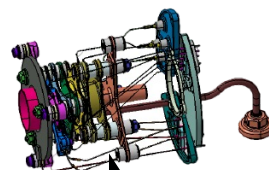

Detector

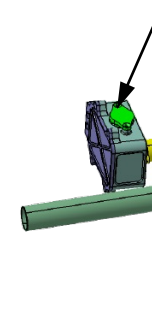

Reflectron

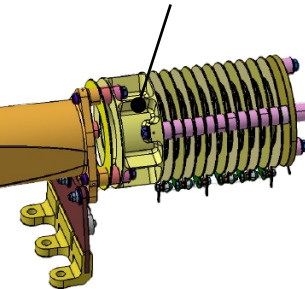

Aperture

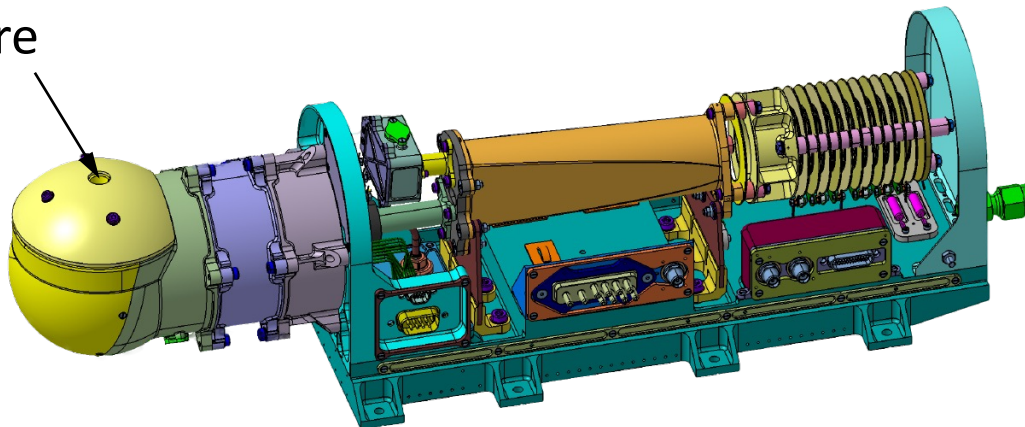

Connectors are flipped to the other side.

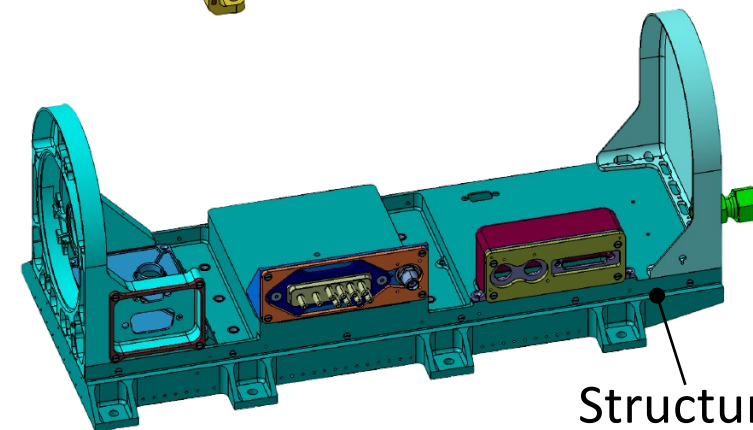

Structure



HV Pulser Board

Mass Analyzer for Neutrals in a Coma (MANiaC) ELU

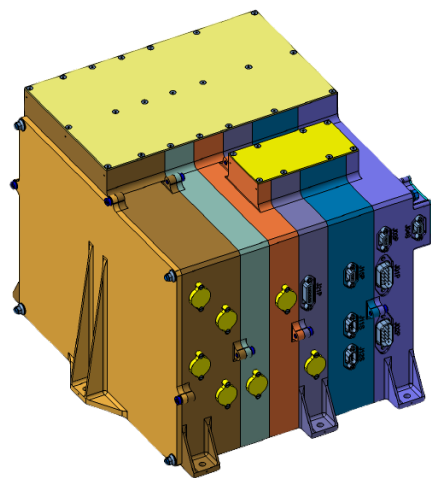

ELU ~4.2 kg*
w/o margin

Backplane

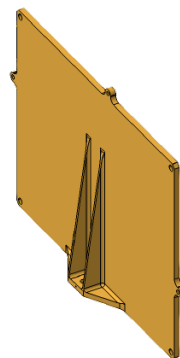
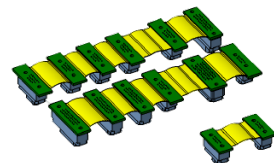

Side Cover / UBE / Swiss Industry

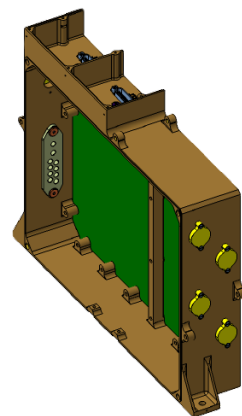

HV / IRAP

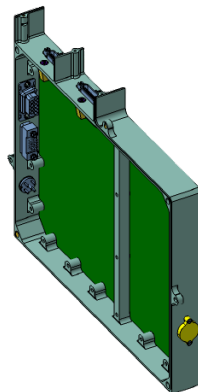

NDG / UBE / Swiss Industry

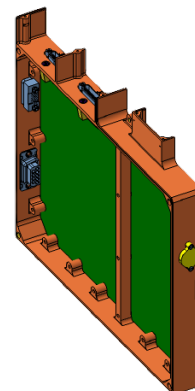

LV+ / UBE / Swiss Industry

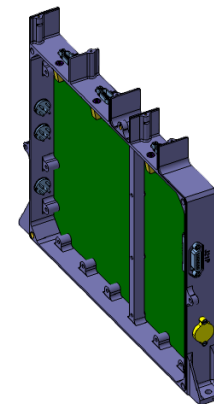

ROE / Creotech

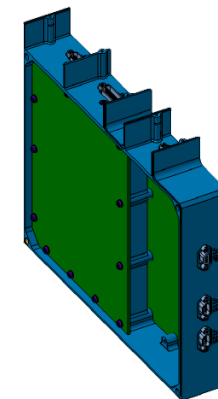

DPU / IWF

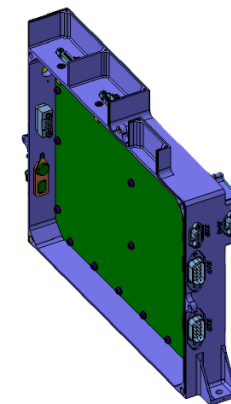

DCC / IAA

Consortium

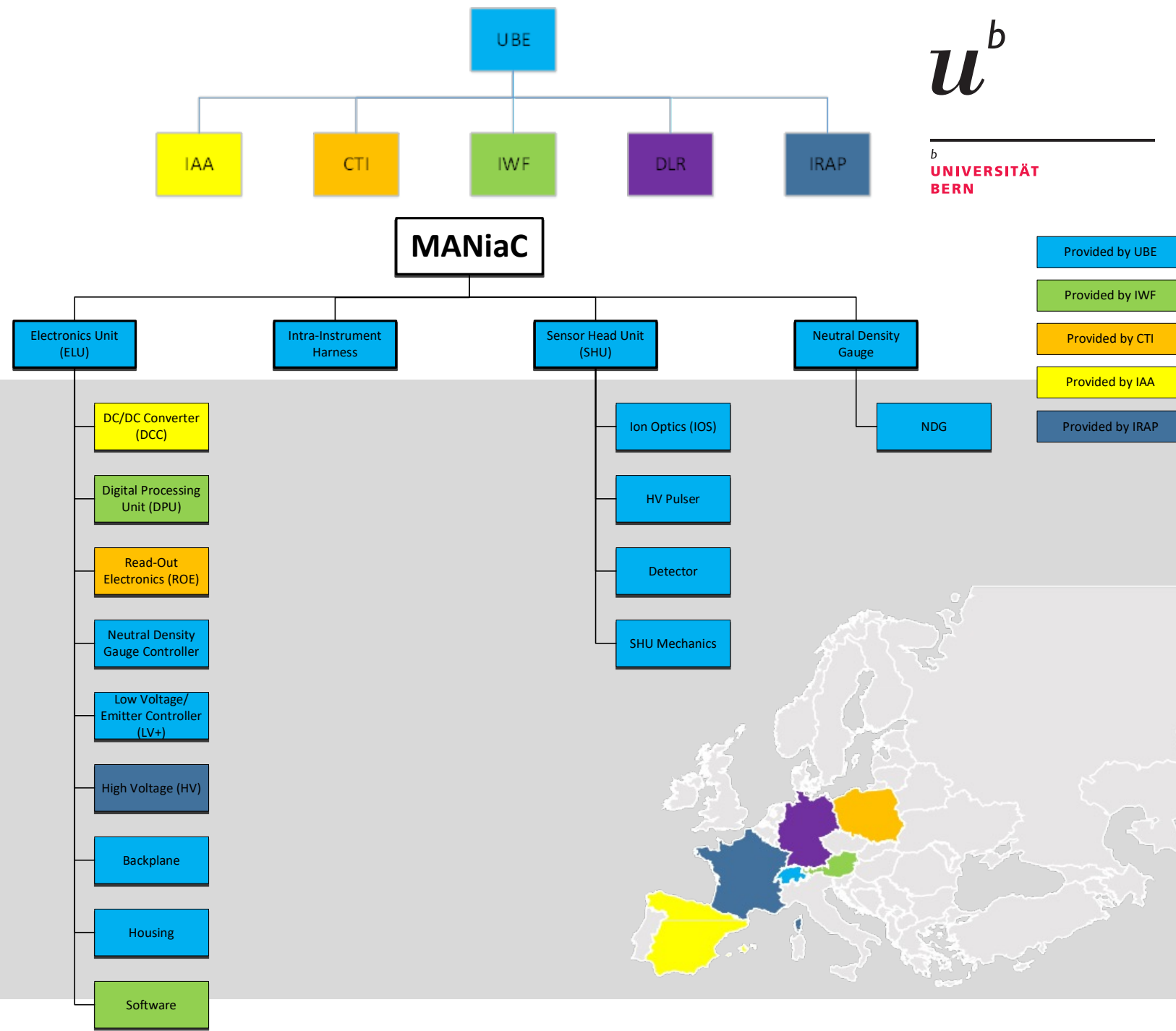

- Instrument consortium is stable.
 - CTI: ROE work towards prototype implementation
 - IRAP: HV activities started
 - IWF/IAA/DLR ongoing

Instrument Science Goals (depend on activity!)

- Monitoring the major volatiles H₂O, CO, and CO₂ in the coma to study the target's activity and associated gas mass loss rate, extended sources, etc.
- Deriving the D/H ratio in H₂O to study the provenience of the water ice in the comet.
- Assess the amount of key volatiles such as O₂ and highly volatile species in a DNC.
- Obtain an inventory of (complex) organic molecules and other species important in pre-biotic chemistry
- Measurement of icy grains' composition should some be collected in the ion source

Flyby & Operation

- Cont. acquisition of mass spectra (SHU) and pressure/density readings (NDG)
- Variable integration times due to changes in coma density and dust impacts

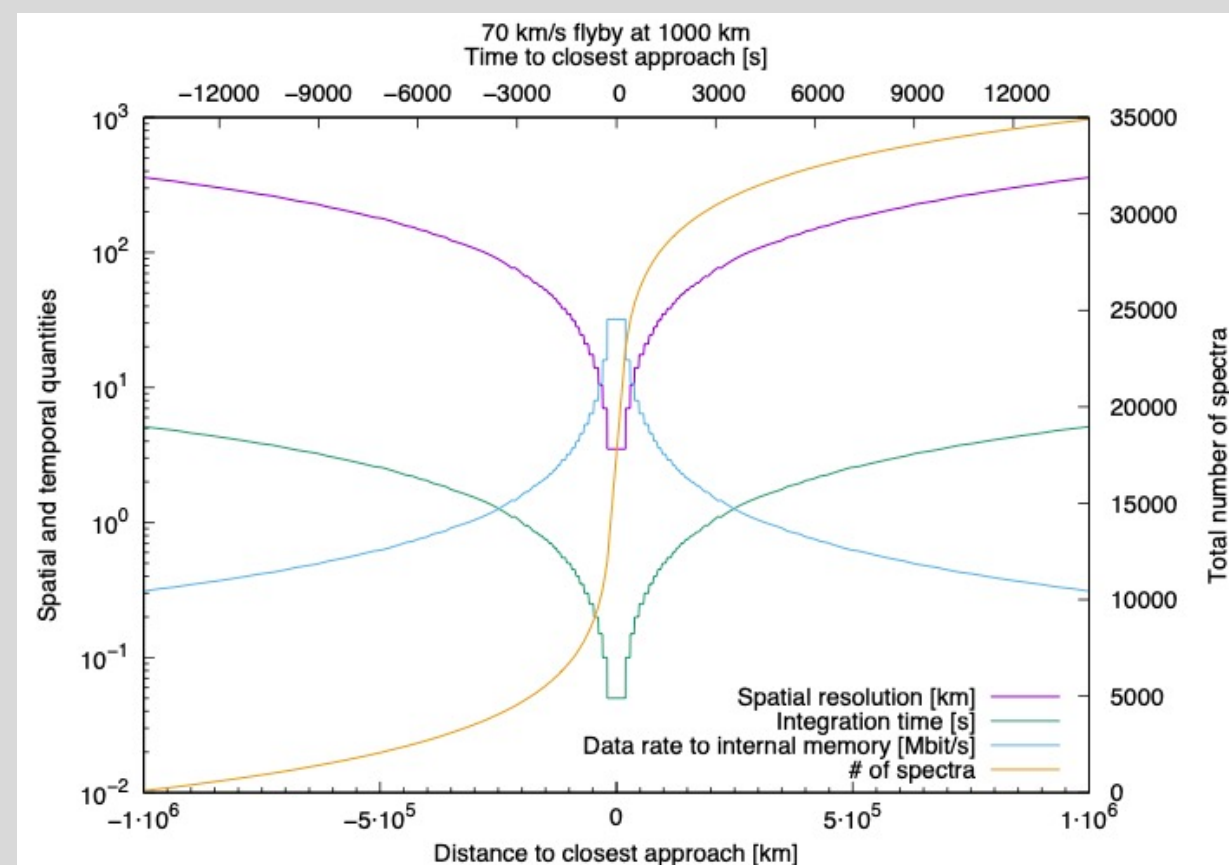
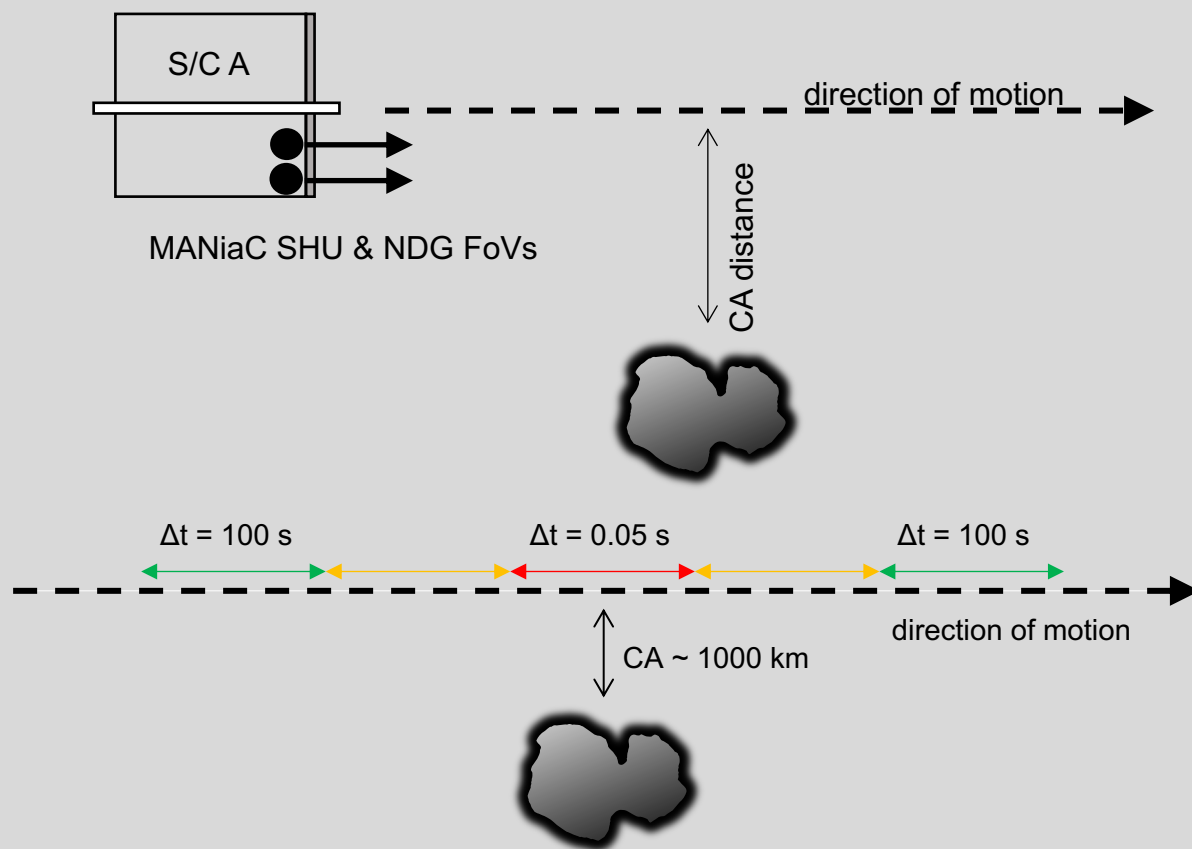

Main design update after I-SRR

- Accommodation clarifications have been performed with the prime contractors. The iterations are almost finished.
- A major open point for the sensors has been shielding implementation. With the preliminary results of the Impact Effect Study the design of the sensors is currently being updated.
- Sun shield is currently being designed

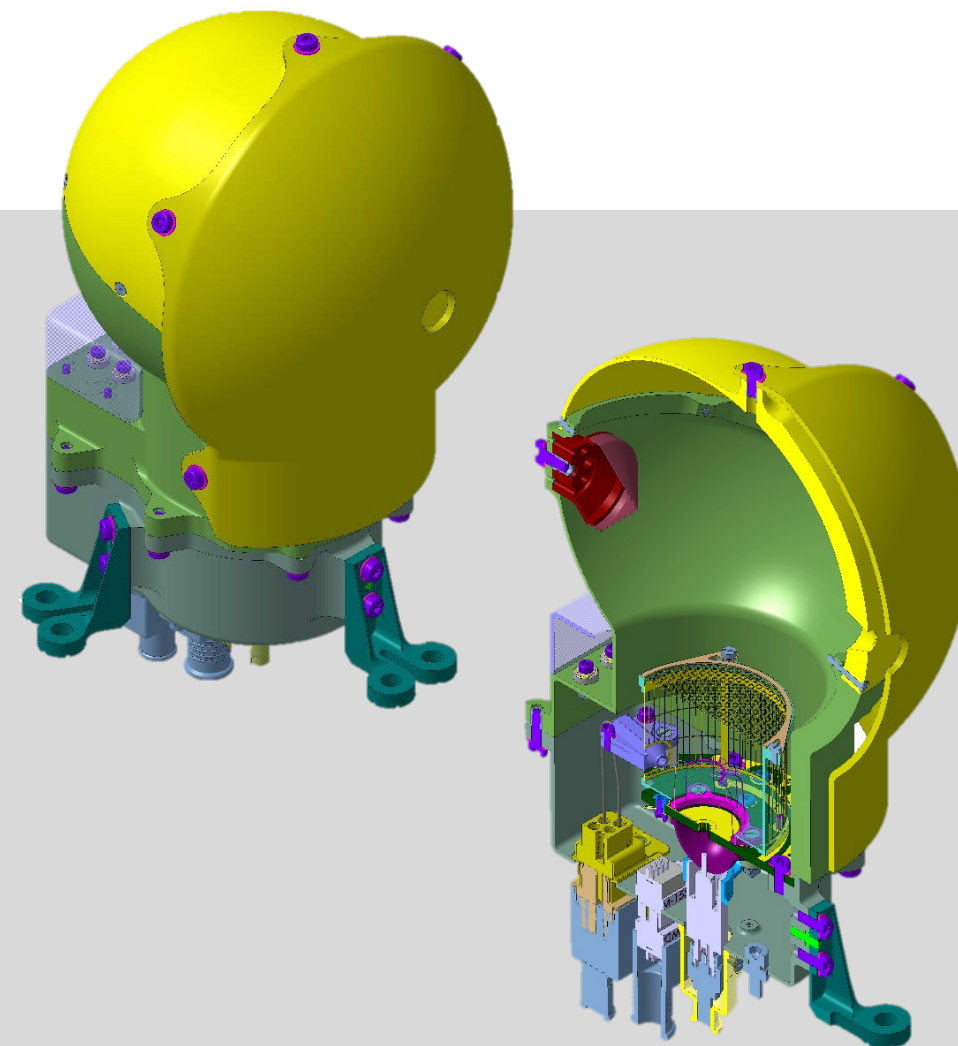

Main design update after I-SRR

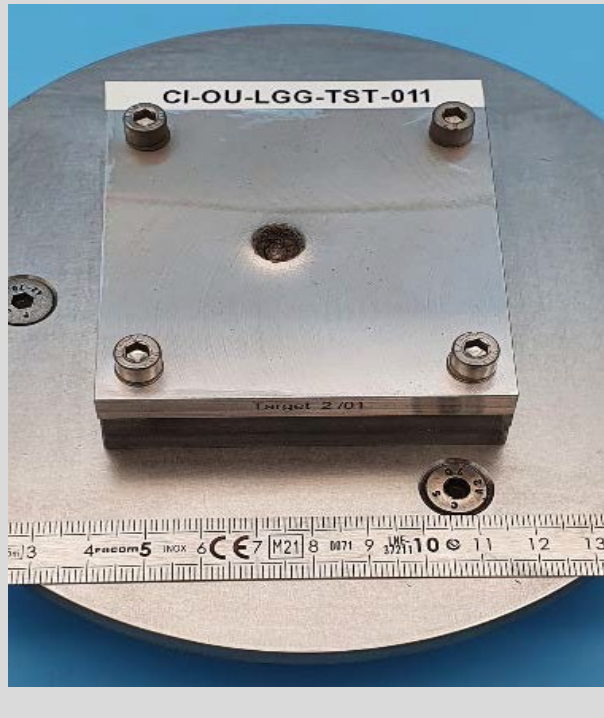
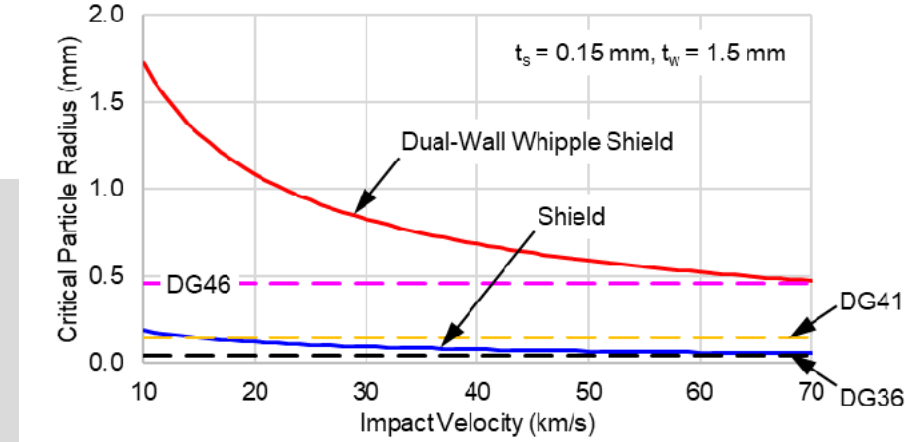
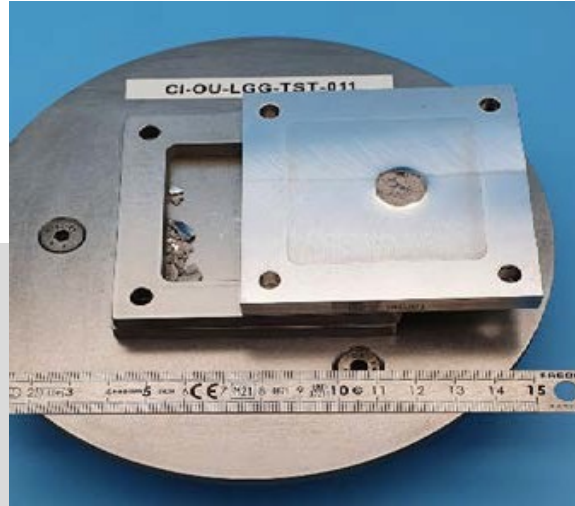

Group #	Grains	Prob.
21	134008	100%
26	5973	100%
31	275	100%
36	14	100%
41	1	52%
46	<1	4%

Group #	Grains	Prob.
21	110261	100%
26	4915	100%
31	226	100%
36	11	100%
41	1	46%
46	<1	3%

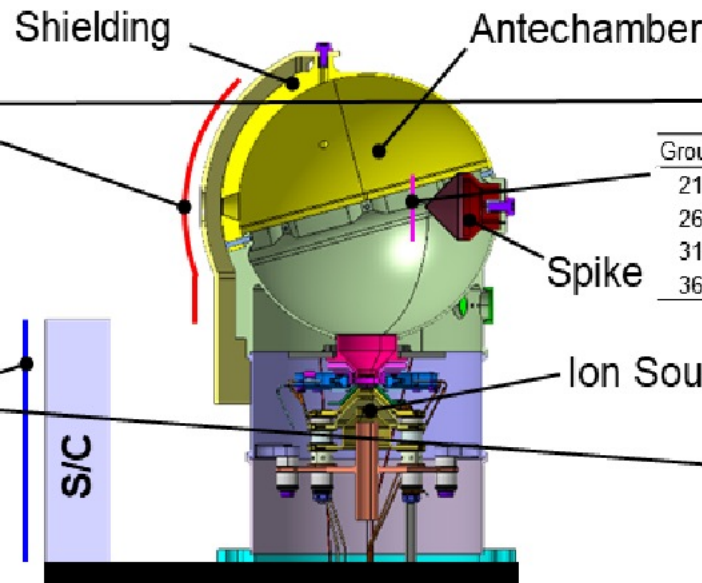

Group #	Grains	Prob.
21	467	100%
26	21	100%
31	1	62%
36	<1	5%

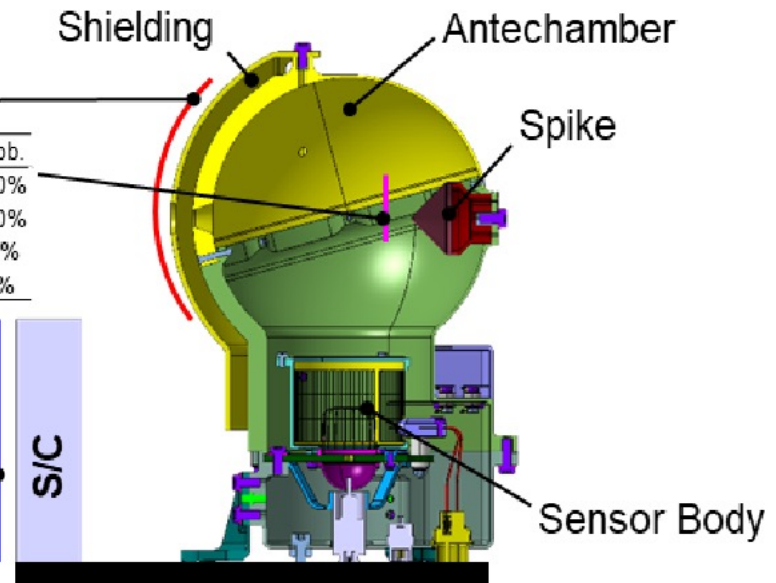

DPU status

- DPU:
 - Performance tests with the GR740 microprocessor development board ongoing.
 - ADC120 evaluation board purchased for SPI HK data acquisition tests.
 - Prototype board (parallel to EM) development ongoing.

Dual board approach
(main and interface board)

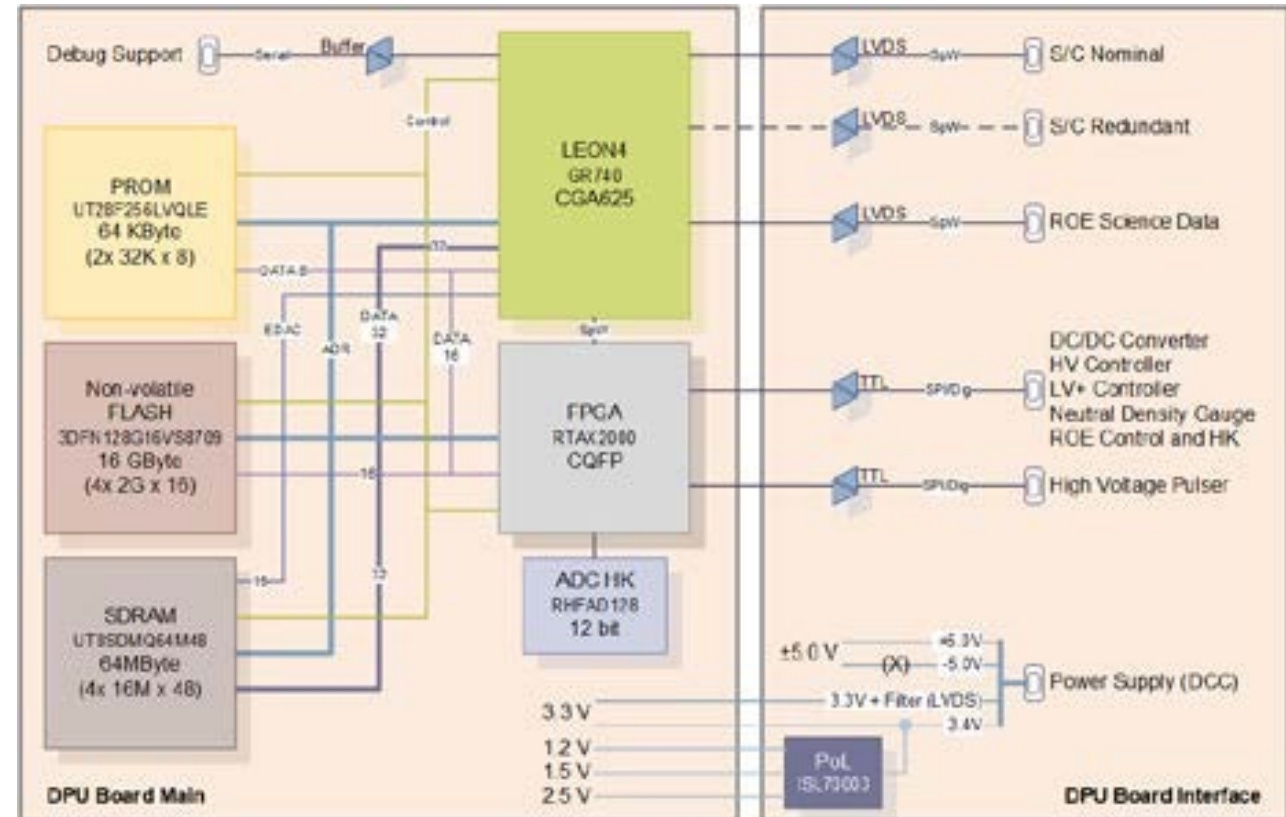

DPU Interface: Power Conditioning & ADC/DAC

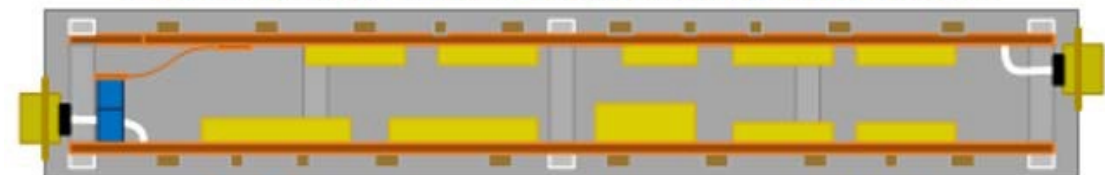

DPU Main: Processor, Memories & FPGA

DCC status

- DCC:
 - EEB1 prototype testing has been finished.
 - EEB2 prototyping expected to be finished in August 2022



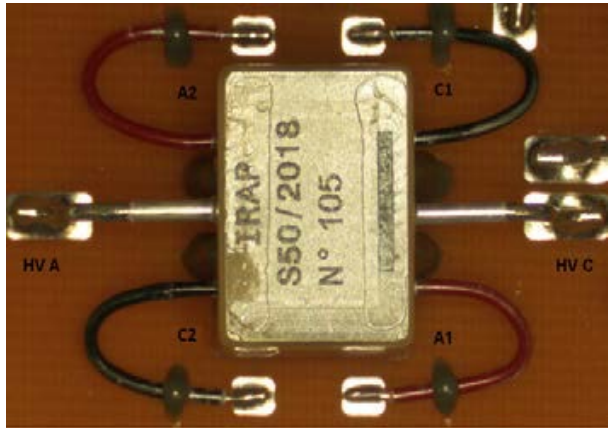

*IRAP's Custom HV
Optocoupler*

- HV:
 - Technological model (TM) development ongoing including optocoupler and custom magnetics (EM to FS) procurement and screening.
 - TM AIV onging.
 - TM will be used as EM after verification.

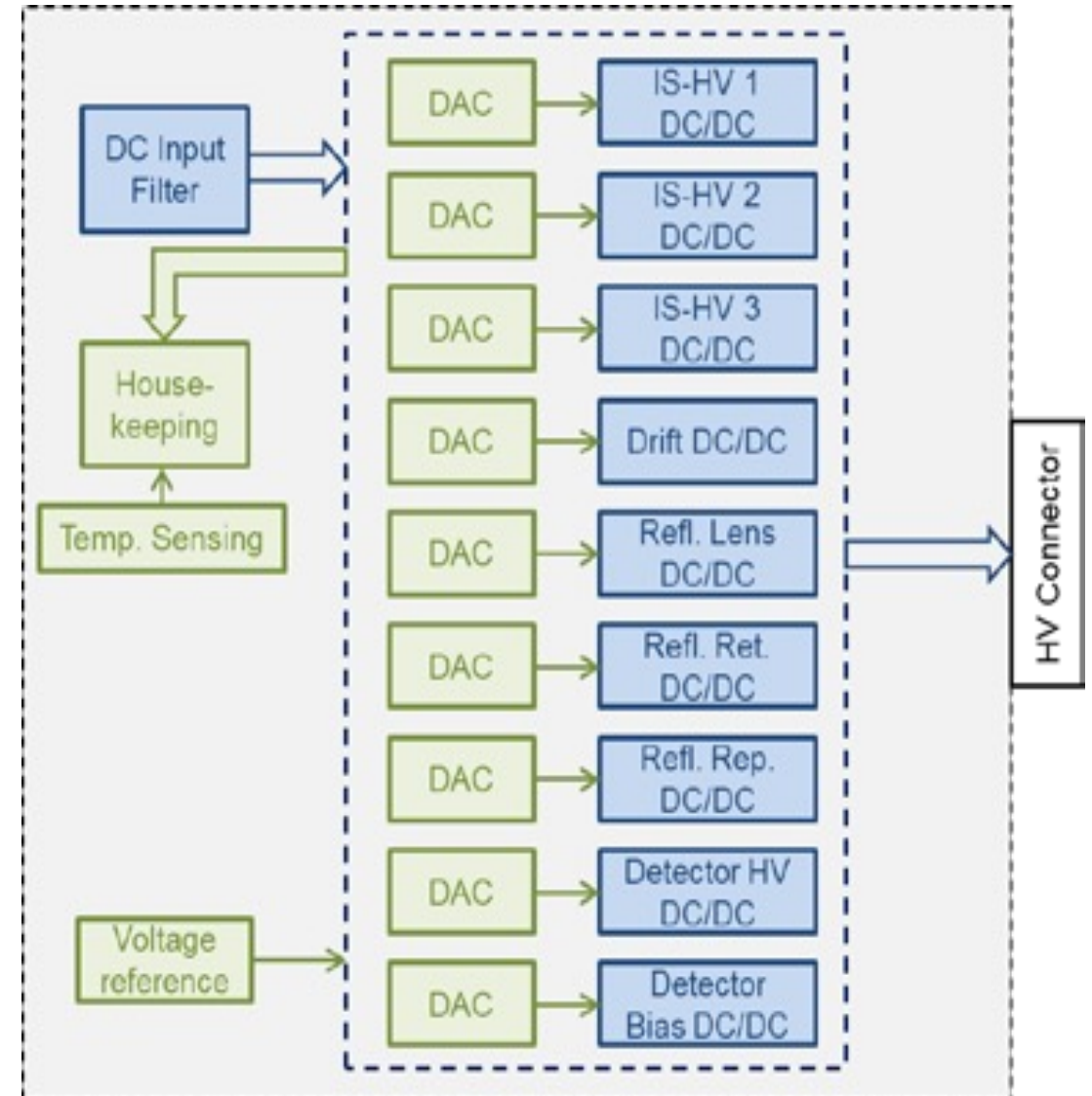

ROE status

- ROE:
 - Development kits procured and evaluation ongoing.
 - FPGA – RTG4 or RT PolarFire (TBC)
 - ADC – ADC12D1620
 - Prototype board will be implemented within summer time frame.

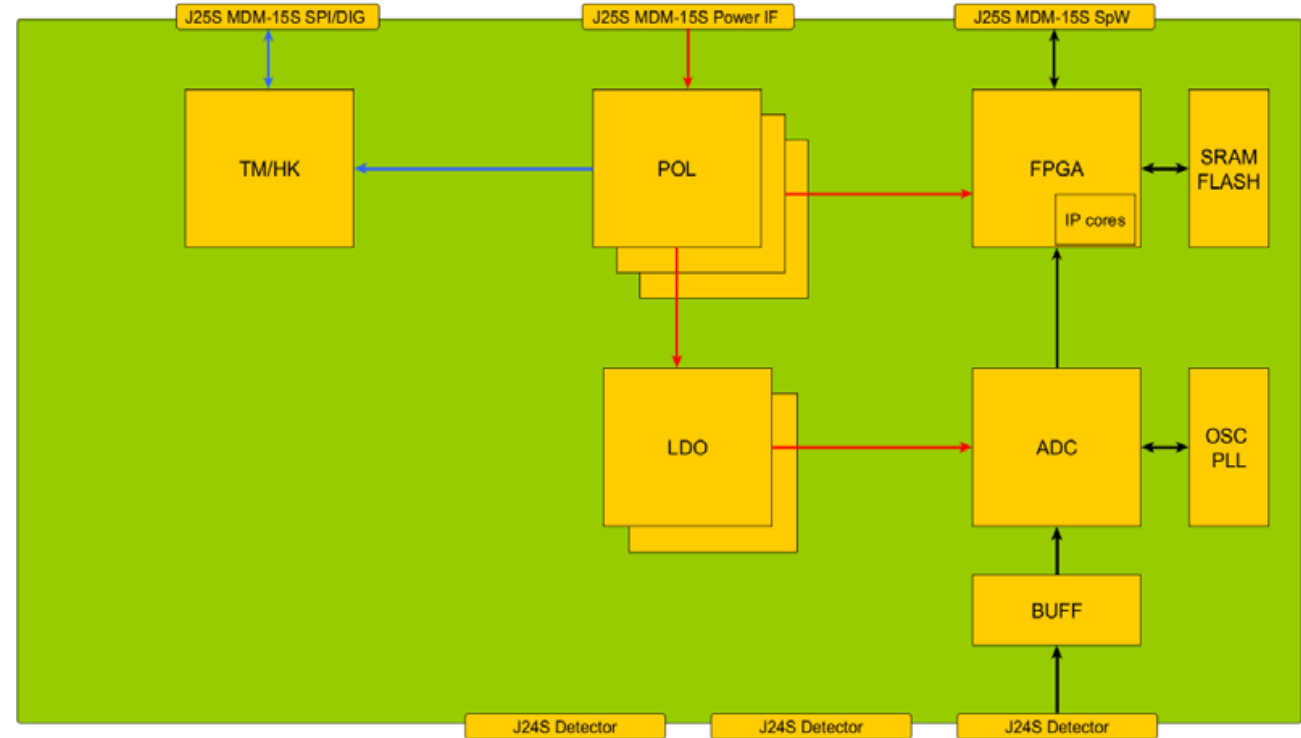

SHU sensor prototype and breadboard testing

- SHU:
 - Mechanical and thermal analysis
 - Mechanical test (shock and random vibration)
 - Partial discharge test
 - Performance simulations in order to verify the SHU design.
 - High voltage pulser electronics verification
 - Performance tests of the ion optics

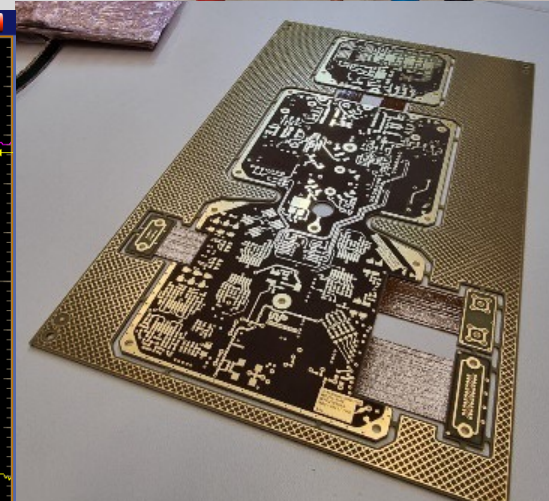
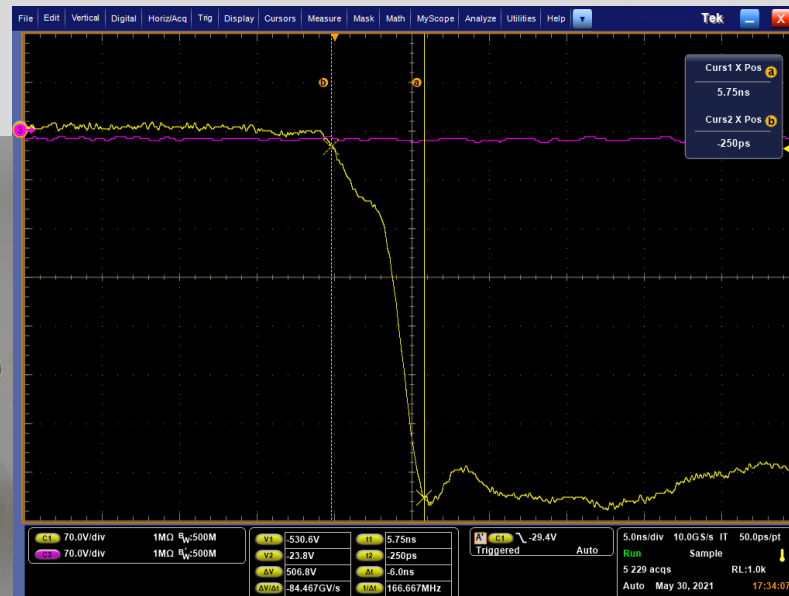
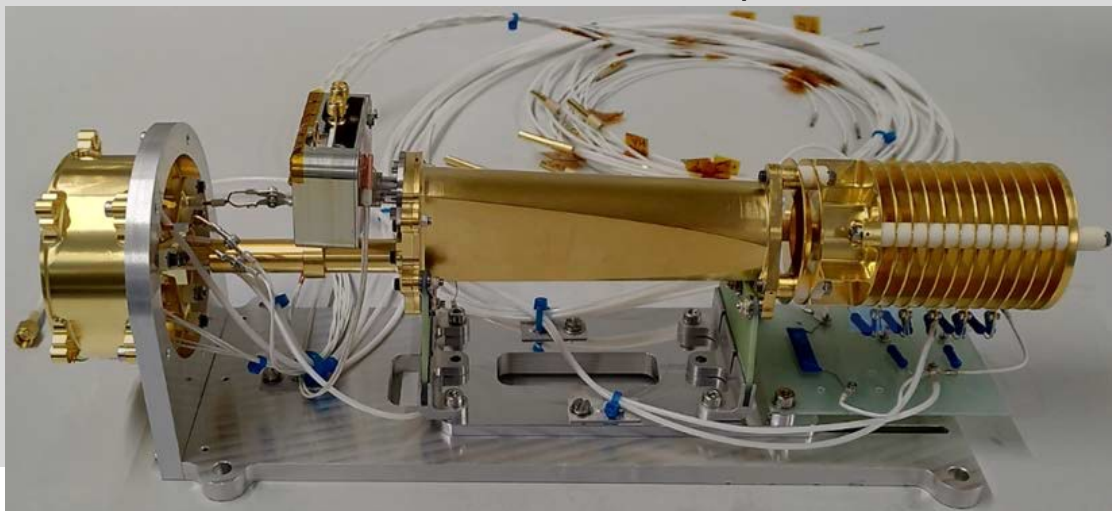
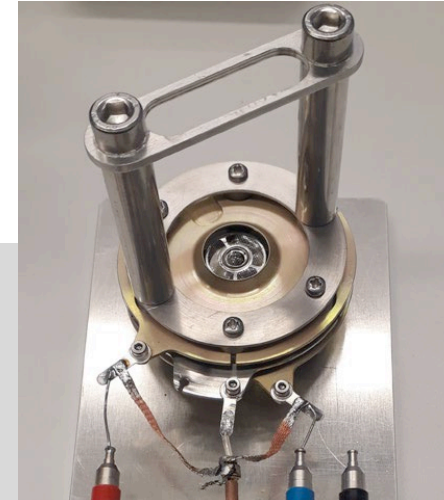
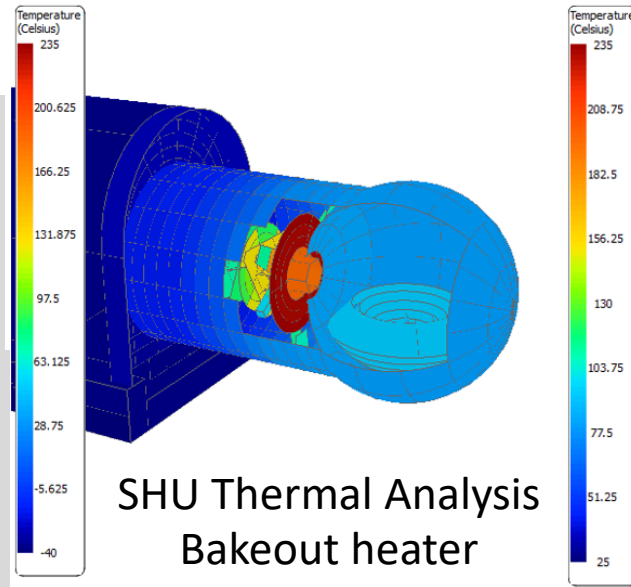

NDG sensor prototype and breadboard testing

- NDG:
 - Mechanical and thermal analysis
 - Mechanical test (shock and random vibration)
 - Measurement front end performance
 - Performance testing (static and dynamic environment)

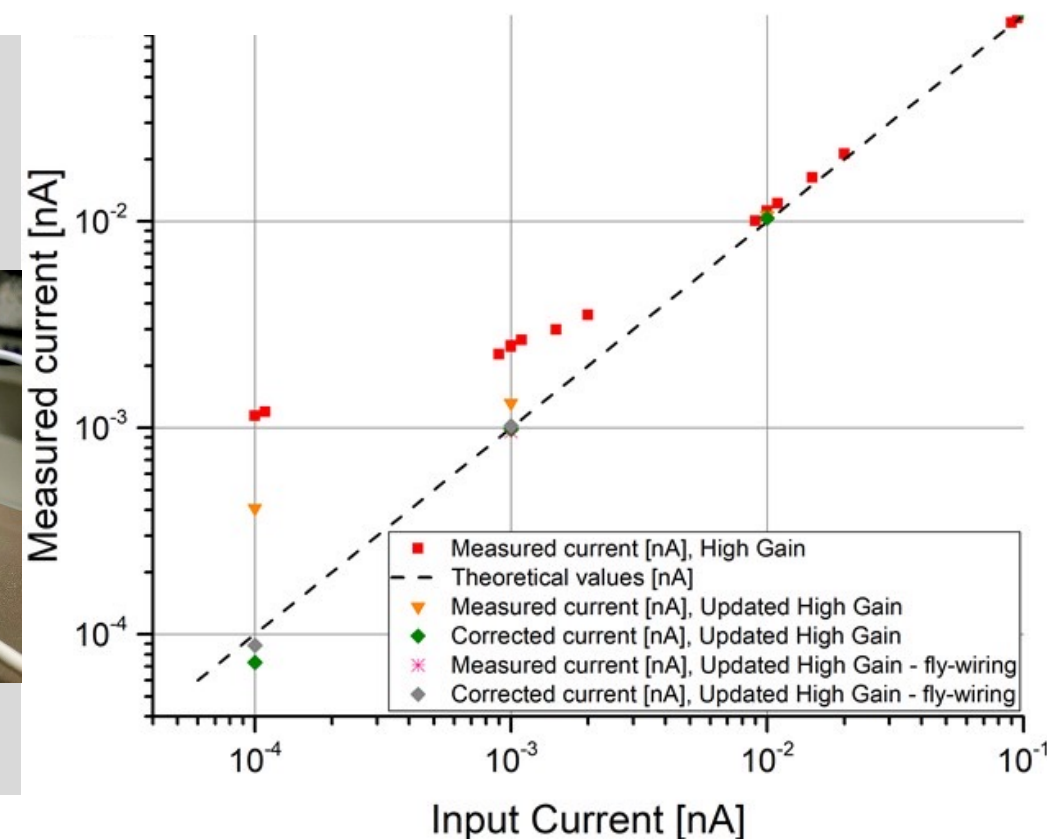
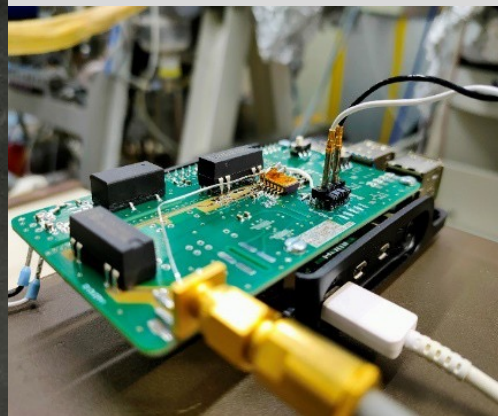
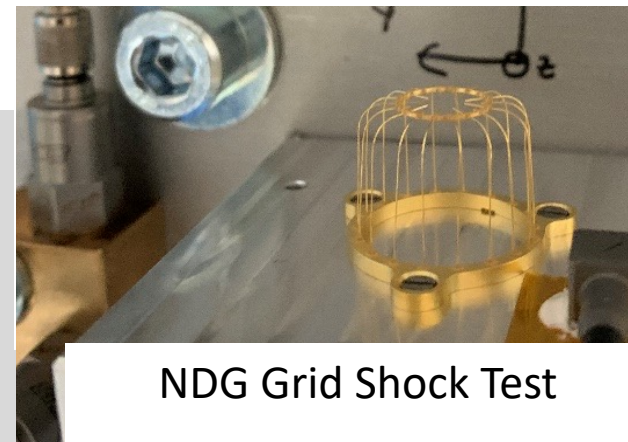

Summary

- MANiaC will measure relative and absolute abundances of volatile species along flyby trajectory (using combined MANiaC MS and NDG data):
 - Volatile abundances: H₂O, CO₂, CO, O₂, ... and possibly distributed sources
 - Isotopes in e.g. H₂O, D/H & ¹⁸O/¹⁶O (depends on activity)
 - Inventory of (complex) organic molecules
 - All measurements are dependent on the activity of the comet and flyby distance
- Consortium is stable
- MANiaC prototype and breadboard testing is progressing within consortium
- Technical budgets considered stable (mass, power, ...).
- Minor design updates for dust and sun shields. Can be finalized only after selection of prime.
- FDIR!